

Remove the Right Side Panel and Top Panel

卸下右側板與上蓋 / Retirez le panneau latéral droit et le capot supérieur / Entfernen Sie die rechte Seitenwand und die obere Abdeckung / Retire el panel lateral derecho y la cubierta superior / 右側のサイドパネルとトップカバーを取り外します

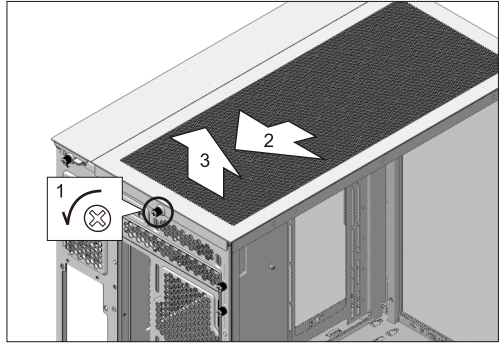
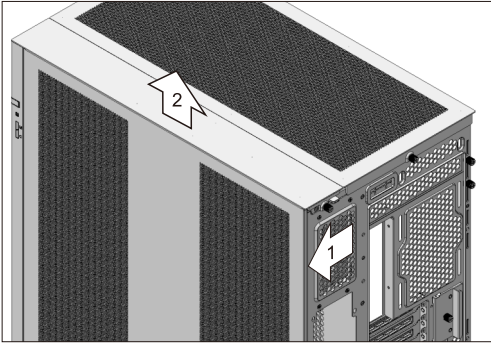

Remove the Side Glass Panel

卸下側玻璃 / Retirer la vitre latérale / Entfernen Sie das Seitenglas / Retire el vidrio lateral / サイドガラスを取り外します

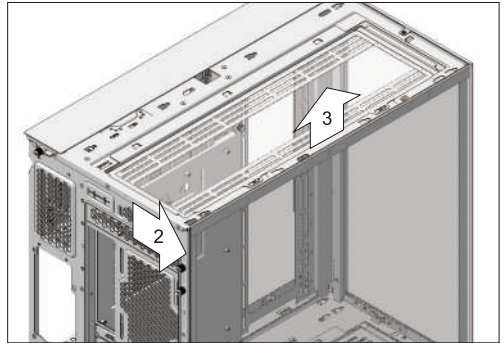
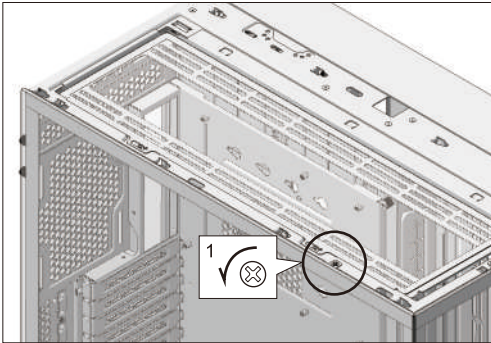

Remove the Front Glass Panel

卸下玻璃前面板 / Retirez le panneau avant en verre / Entfernen Sie die Glasfrontplatte / Retire el panel frontal de vidrio / ガラスのフロントパネルを取り外します

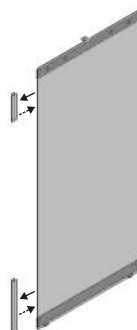
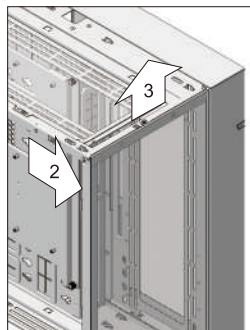
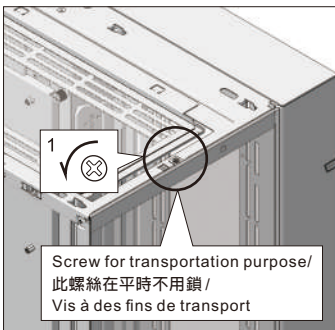

Remove the 2 side protecting clip before installation/
安裝前記得要移除側邊的兩個保護膠條/
Retirez les 2 clips de protection latéraux avant l'installation

Recommend to keep the protecting clip on for transportation/
如需運送建議將保護膠條裝上/
Il est recommandé de conserver le clip de protection pour le transport

Normal

Normal Mode Specifications

正常模式規格 / Spécifications du mode normal / Spezifikationen für den Normalmodus / Especificaciones del modo normal / 通常モードの仕様



Refer to page 1-15, 28 to install this mode / 要安裝此模式，請參閱第 1-15、28 頁 /
Reportez-vous aux pages 1-15, 28 pour installer ce mode

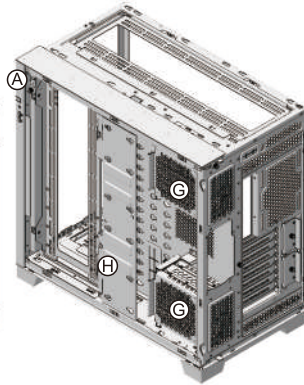
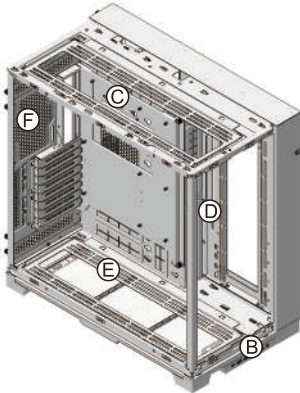

- (A) Power Button, Reset Button, C button for color control, M button for lighting mode control
- (B) IO ports: 1 x AUDIO / Microphone Combo Jack, 4 x USB 3.0, 1 x USB 3.1 Type C
- (C) Supporting 120 mm fan x 3 or 140 mm fan x 3 or 360 mm radiator x 1 or 420 radiator x 1
- (D) Supporting 120 mm fan x 3 or 140 mm fan x 3 or 360 mm radiator x 1 or 420 radiator x 1
- (E) Supporting 120 mm fan x 3 or 140 mm fan x 3 or 360 mm radiator x 1 or 420 radiator x 1
- (F) Supporting 120 mm fan x 1 or 2
- (G) Hot swappable drive trays:
Supporting 3.5" HDD x 2 or 2.5" SSD x 2
- (H) Removable HDD tray,
Supporting 2.5" SSD x 3

Reverse

Reverse Mode Specifications

倒置模式規格 / Spécifications du mode inversé / Spezifikationen für den Rückwärtsmodus / Especificaciones del modo inverso / リバースモード仕様





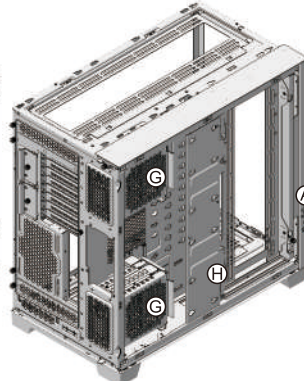
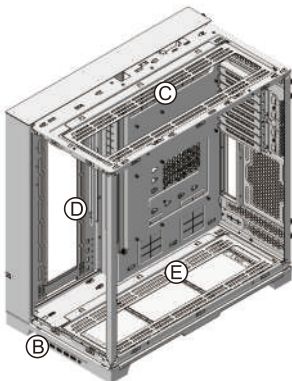





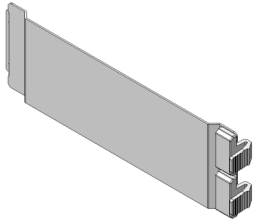
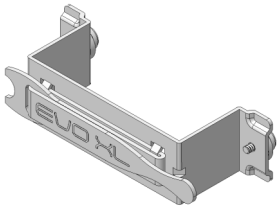

Refer to page 1-4, 16-28 to install this mode / 要安裝此模式，請參閱第 1-4、16-28 頁 /
Reportez-vous aux pages 1-4, 16-28 pour installer ce mode









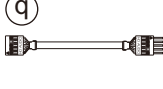

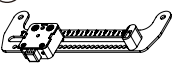
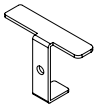
- (A) Power Button, Reset Button, C button for color control, M button for lighting mode control
- (B) IO ports: 1 x AUDIO / Microphone Combo Jack, 4 x USB 3.0, 1 x USB 3.1 Type C
- (C) Supporting 120 mm fan x 3 or 140 mm fan x 3 or 360 mm radiator x 1 or 420 radiator x 1
- (D) Supporting 120 mm fan x 3 or 140 mm fan x 3 or 360 mm radiator x 1 or 420 radiator x 1
- (E) Supporting 120 mm fan x 3 or 140 mm fan x 3 or 360 mm radiator x 1 or 420 radiator x 1
- (F) Supporting 120 mm fan x 1 or 2
- (G) Hot swappable drive trays:
Supporting 3.5" HDD x 2 or 2.5" SSD x 2
- (H) Removable HDD tray,
Supporting 2.5" SSD x 3

Hardware List

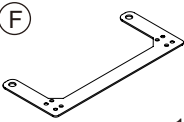
零件部品一覧表 / Liste du matériel / Hardwareliste / Lista de hardware / ハードウェアリスト

 <p>(a) x 2</p>	 <p>(b) x 1</p>	 <p>(c) x 25</p>
<p>Fan bracket cover</p>	<p>Cable buckle</p>	<p>Screws for motherboard/ 2.5" SSD mounting</p>
 <p>(e) x 12</p>	 <p>(f) x 12</p>	 <p>(g) x 8</p>
<p>Anti-vibration rings for 2.5" SSD / 3.5" HDD mount</p>	<p>Screws for 2.5" SSD mount</p>	<p>Screws Install 15 mm thick fan</p>
 <p>(j) x 1</p>	 <p>(k) x 4</p>	 <p>(l) x 1</p>
<p>Tool for stand-off bolt</p>	<p>Screws for fan mounting</p>	<p>Name plate</p>
 <p>(o) x 16</p>	 <p>(p) x 7</p>	 <p>(q)</p>
<p>Screws for 3.5" HDD mount</p>	<p>Cable ties for cable management</p>	<p>Extension cable for HD audio cable at reversed mode</p>
<p>※ Exceeded quantity are spare parts. ※ 多餘的零件數量是備品。 ※ Les pièces supplémentaires sont des pièces de rechange. ※ Zusätzliche Teile können als Ersatzteile verwendet werden. ※ Exceeded quantity are spare parts. ※ ネジには予備が含まれてています。</p>		

 <p>(A) x 1</p>	 <p>(B) x 1</p>	 <p>(C) x 2</p>	 <p>(D) x 2</p>	 <p>(E) x 3</p>
<p>Tool/工具/Outil</p>				
 <p>(F) x 1</p>	 <p>(G) x 2</p>	 <p>(H) x 2</p>	 <p>(I) x 2</p>	 <p>(J) x 2 (L) x 2 (K) x 2</p>

For graphic card anti-sag bracket kit installation/用於顯卡防下垂支架套件安裝/Pour l'installation du kit de support anti-affaissement de la carte graphique

I/O Ports Function

I/O port 功能說明 / Installation du port I/O / I/O-Port installieren / Instalación de los puertos de I/O / I/Oポート機能

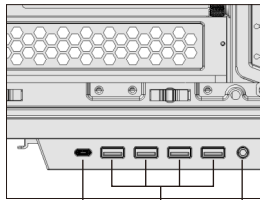
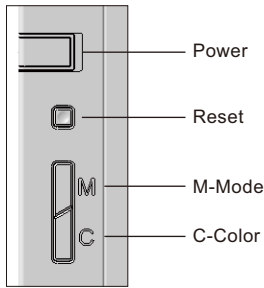

USB 3.1 Type C
USB 3.0
Microphone Combo Jack

M-Mode / M-Mode / Mode M	Press one time / 按一次 / Appuyez une fois	7 Lighting Effects: Rainbow – Rainbow Morph – Dual Runway** – Color Bump – Meteor** – Colorful Runway – Single Meteor **able to change color by pressing C / 7 種燈光效果：彩虹- 彩虹漸變- 雙色跑馬** - 雙色對撞- 流星**- 彩色跑馬- 單次流星 **按 C 鍵可換顏色 / 7 effets d'éclairage : Rainbow – Rainbow Morph – Piste double** – Relief de couleur – Météore** – Piste colorée – Météore unique **capable de changer de couleur en appuyant sur C
	Long press 3 sec / 長按 3 秒 / Appuyez longuement 3 secondes	Sync to MB or L-Connect (Press M one time to turn off sync) / 同步主板或 L-Connect(按一次 M 關閉同步) / Synchroniser avec MB ou L-Connect (Appuyez une fois sur M pour désactiver la synchronisation)
C-Color / C- 顏色 / C-Couleur	Press one time / 按一次 / Appuyez une fois	Static Color: White – Red – Green – Blue – Yellow – Light Blue – Purple / 定色：白-紅-綠-藍-黃-淺藍-紫 / Couleur statique: Blanc – Rouge – Vert – Bleu – Jaune – Bleu clair – Violet
	Long press 3 sec / 長按 3 秒 / Appuyez longuement 3 secondes	Turn off LED (Press C or M one time to turn on LED) / 關閉燈光 (按 C 或 M 一次開啟燈光) / Éteindre la DEL (Appuyez une fois sur C ou M pour allumer la LED)

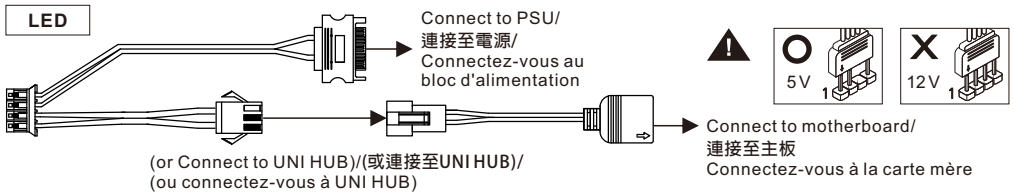

POWER / RESET



Definition	
1	Power LED+
3	Power LED-
5	Power SW+
7	Power SW-
6	Reset SW+
8	Reset SW-

USB 3.0

Supports motherboard USB 3.0 20 Pin header

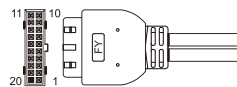

HD AUDIO

Blue	10	9	Green
Black purple	8	7	Key
Yellow	6	5	Orange
Gray	4	3	N.C.
Red	2	1	GND+H.S. TUBE

USB 3.1 GEN.2

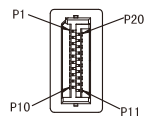

2.5" SSD Installation

2.5" SSD 安裝 / Installation de 2.5" SSD /

2.5" SSD-Installation / Instalación de 2.5" SSD /

2.5" SSD の取り付け

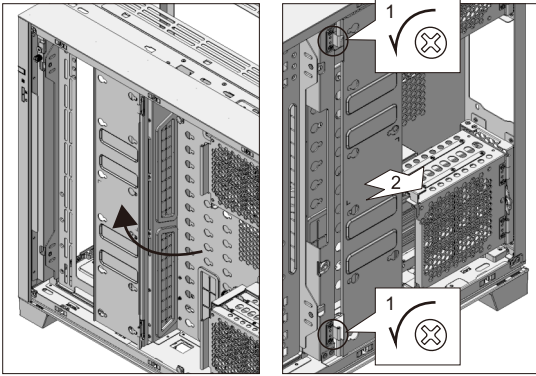

Way 1: Swing 180° to open/
使用方式一：翻轉180度/
Méthode 1 : Pivoter à 180°
pour ouvrir

Way 2: Release /
使用方式二：取下/
Voie 2 : Libérer

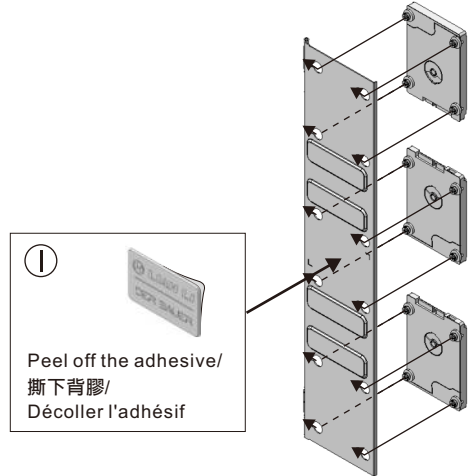
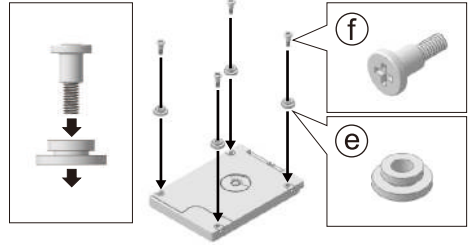

PSU Installation

電源供應器安裝 /

Installation du plateau du bloc d'alimentation /

PSU-Einsatz installieren /

Instalación de la fuente de alimentación /

電源のインストール

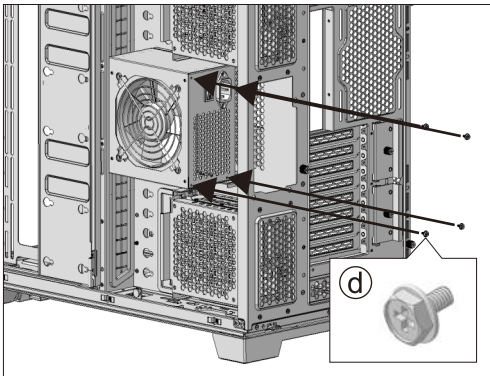

Remove the Dust Filter

灰塵濾網拆卸 /

Retirer le filtre à poussière /

Entfernen Sie den Staubfilter /

Retire el filtro de polvo /

防塵フィルターを取り外す

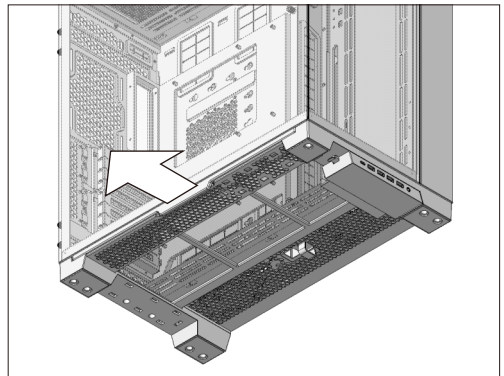

IO Module Location

I/O port 位置變換 / Changement de position du port d'E/S / Positionsänderung des I/O-Ports /
Cambio de posición del puerto de E / S / I/Oポートの位置変更

Location 1 (Default mode) / 位置 1 (預設模式) /
Emplacement 1 (mode par défaut)

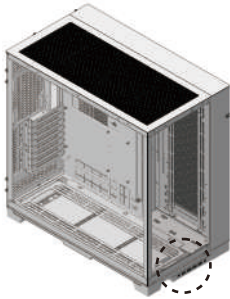
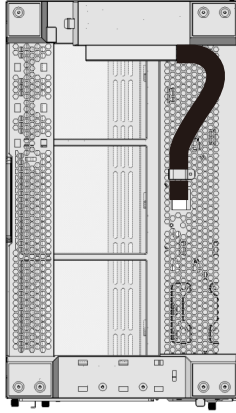

Location 2 / 位置 2 /
Emplacement 2

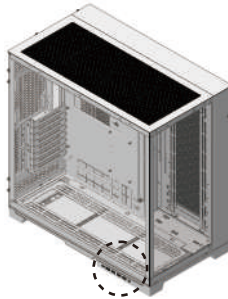
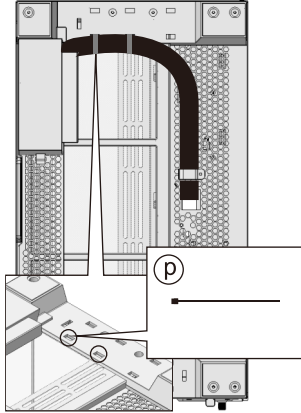

Location 3 / 位置 3 /
Emplacement 3

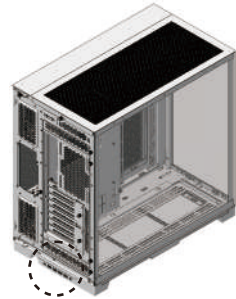
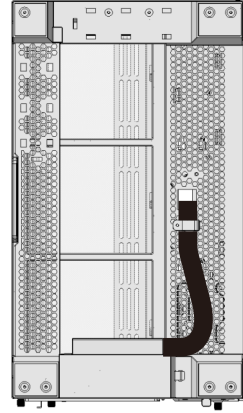

Remove the IO module / IO port 卸除 /
Retirer le module IO

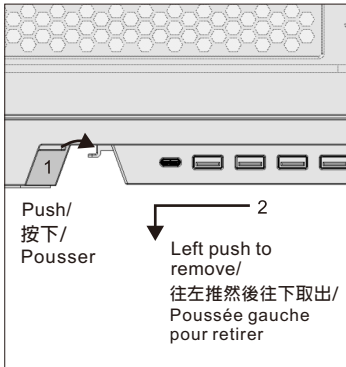

Remove the cable clip /
整線扣卸除 /
Retirer le serre-câble

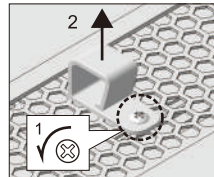

Install the cable clip /
整線扣安裝 /
Installez le serre-câble

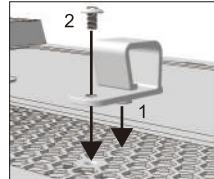

Route and fix the cable in different direction /
線材換方向走線固定 /
Acheminez et fixez le câble dans une direction
différente

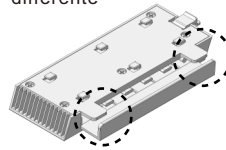

Move the cables to the
opposite direction
through the gap /
藉由缺口將線材拉出與
裝入凹位 /
Déplacez les câbles dans
la direction opposée à
travers l'espace

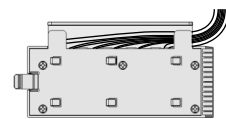

Cable orientation
for location 1 & 2 /
位置 1、2 適用 /
Orientation des
câbles pour les
emplacements 1 et 2 /

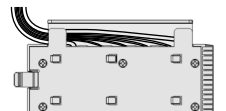

Cable orientation
for location 3 /
位置 3 適用 /
Orientation des câbles
pour l'emplacement 3

Remove the motherboard tray and back plate

卸除後板與遮片 / Retirez le panneau arrière et le masque / Entfernen Sie die Rückwand und die Maske /
Retire el panel posterior y la máscara / バックパネルとマスクを取り外します

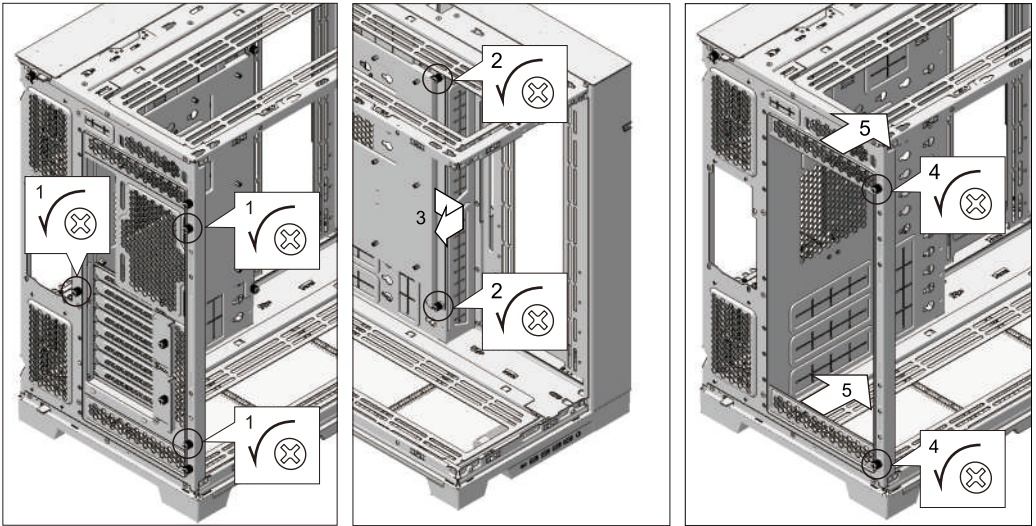

Motherboard Installation

主板安裝 / Installation de la carte mère / Mainboard-Installation / Instalación de la placa base /
マザーボードの取り付け

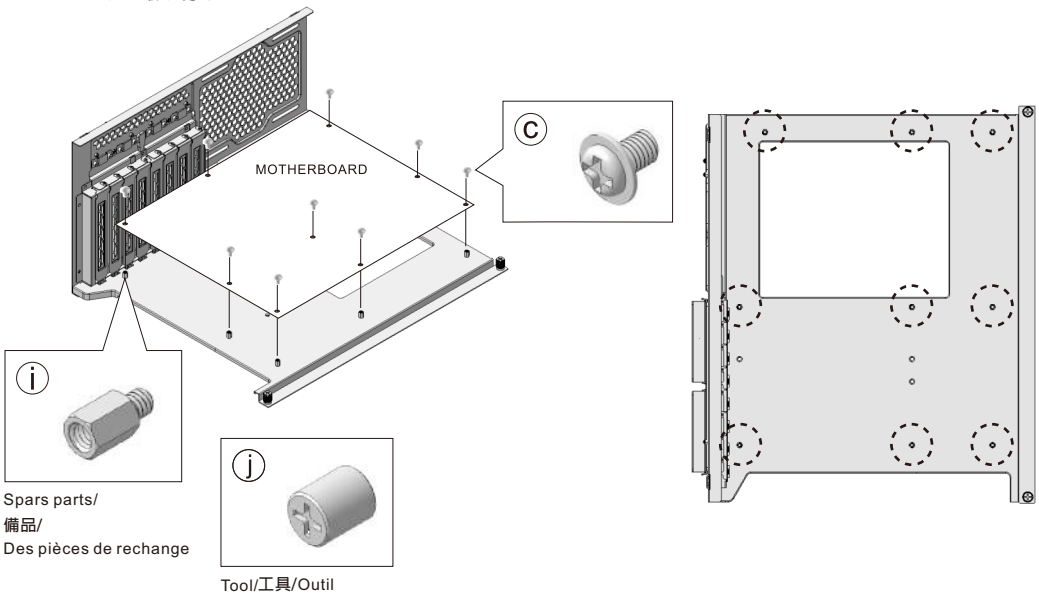

Install the Back Plate and the Motherboard Tray

安裝後板與遮片 / Installez la plaque arrière et le masque / Installieren Sie die Rückplatte und die Maske /
Instale la placa posterior y la máscara / バックプレートとマスクを取り付けます

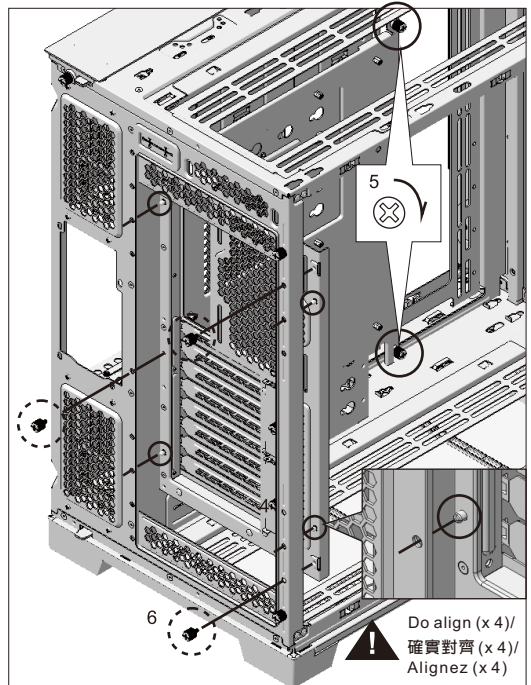
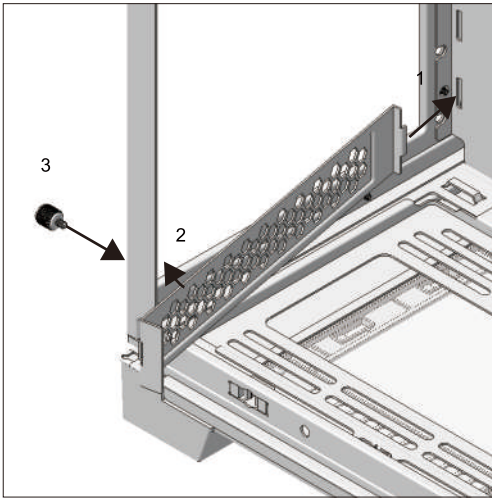

Schema of the Modes

配置示意圖 / Schéma de configuration / Konfigurationsdiagramm /
Diagrama de configuración / 構成のヒント

○ Screw here
圓框處請鎖上螺絲
Visser ici

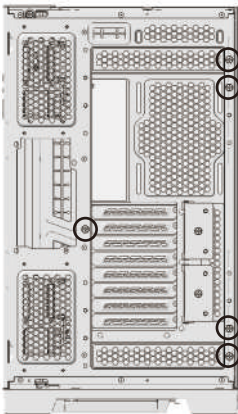

Middle Mode (Factory Default) / 出廠配置 /
Mode moyen (valeur par défaut)

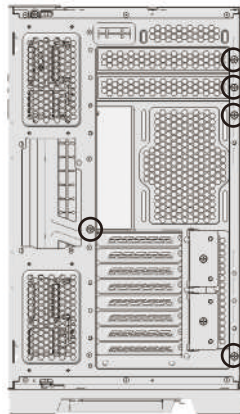

Low Mode / 下置配置 /
Mode bas

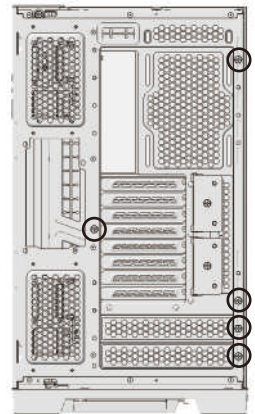

Top Mode / 上置配置 /
Mode supérieur

Graphics card installation

顯示卡安裝 / Installation de la carte graphique / Grafikkarteninstallation /
Instalación de tarjeta gráfica / グラフィックカードの取り付け

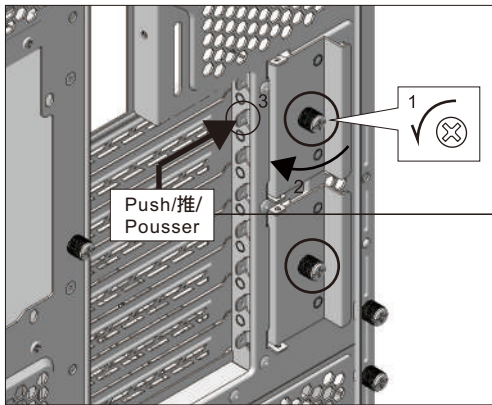

Push to release bracket/
推開拿出空片/
Pousser pour libérer le support

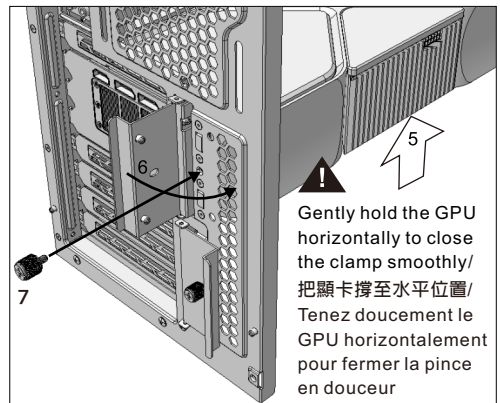
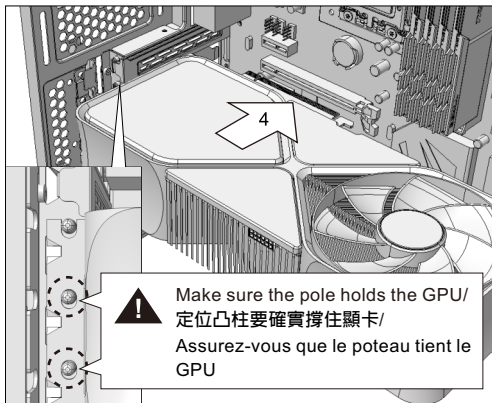

Remove the pillar

立柱卸除方式 / Column removal method /
Methode zum Entfernen von Säulen /
Método de eliminación de columnas /
カラムの取り外し方法

! Make sure to fix the pillar for transporting/
如需運送，務必將立柱鎖上/
Assurez-vous de fixer le pilier pour le transport

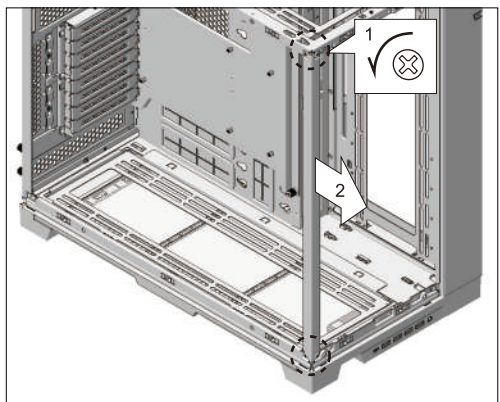

2.5" SSD, 3.5" HDD Installation

2.5" SSD, 3.5" HDD 安裝 / Installation de 2.5" SSD, 3.5" HDD / 2.5" SSD, 3.5" HDD-Installation /
Instalación de 2.5" SSD, 3.5" HDD / 2.5" SSD, 3.5" HDD の取り付け

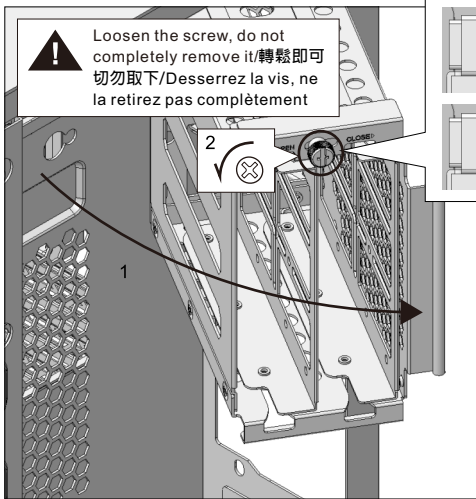

15 mm thick fans can be installed outside the HDD cage/硬碟籠外側可安裝 15 mm 厚度風扇 / Des ventilateurs de 15 mm d'épaisseur peuvent être installés à l'extérieur de la cage HDD

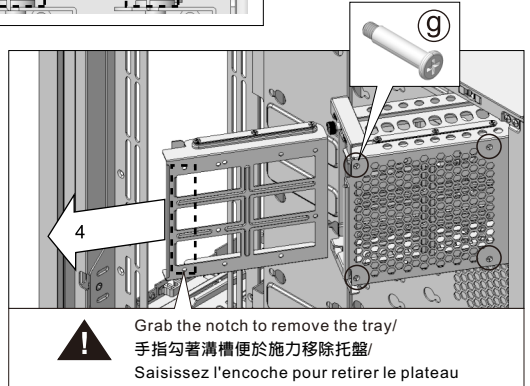

2.5" SSD Installation

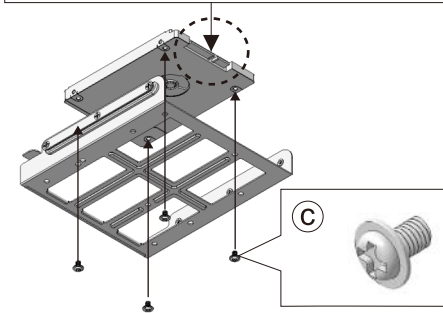
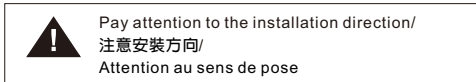

3.5" HDD Installation

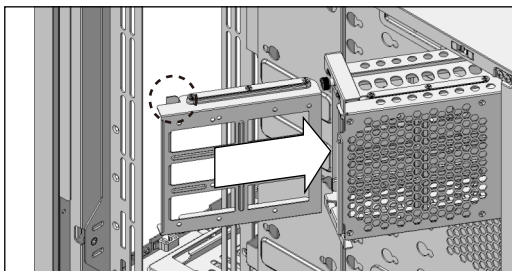
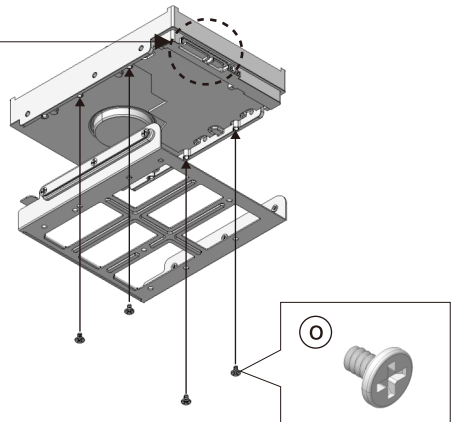

Cable connection/線材連接 / Câble de connexion

-  Connecting to Motherboard / 連接至主板 / Connexion à la carte mère
-  Connecting to PSU / 連接到電源 / Connexion au bloc d'alimentation

Cable Management

線材整理 / Gestion des câbles / Kabelmanagement /
Mantenimiento de cable / ケーブル管理

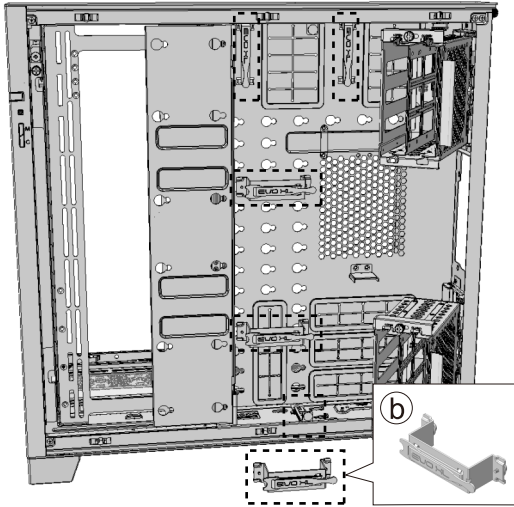

Cable Holder Installation

整線扣安裝方式 / Installation complète de la boucle du
câble / Installation der gesamten Kabelschnalle /
Instalación de hebilla de cable completo /
全ラインバックルの取り付け

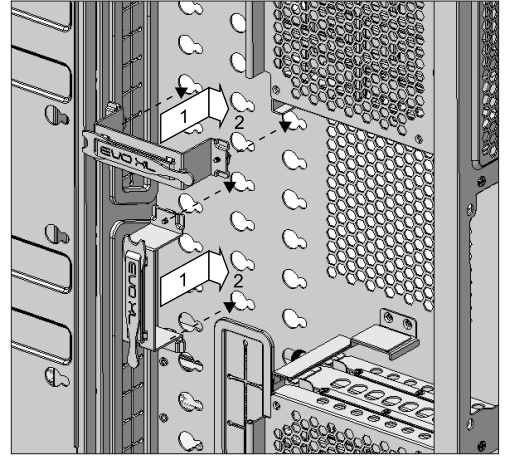

Use of Cable Holder

整線扣整線說明 / Description complète de la ligne complète de la boucle du câble / Ganze Beschreibung der
gesamten Kabelschnalle / Descripción de toda la línea de hebilla de cable completo / バックル全体 ライン全体

Keep the big cables in the cable holders/
先將粗線整在金屬框架內/
Gardez les gros câbles dans les
porte-câbles

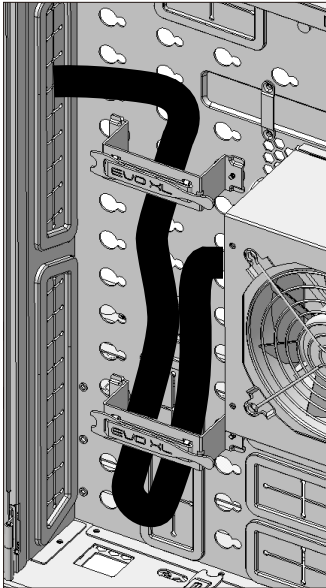

Hold the small cables with the velcro straps/
再將細線使用魔鬼氈整好/
Maintenez les petits câbles avec les bandes
velcro

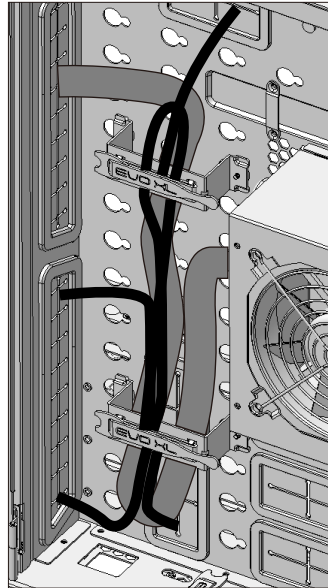

Remove the velcro strap to place a
controller/
亦可拆下魔鬼氈作為控制器黏貼處/
Retirez la bande velcro pour placer un
contrôleur

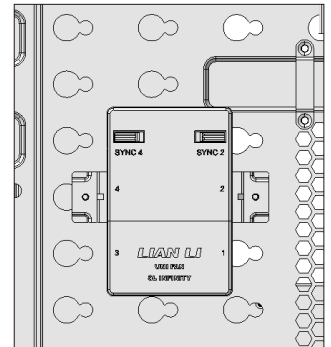

Radiator & Cooling Support

散熱器&水冷排支援 / Radiateur et ventilation compatibilité / Kühler- und Kühlungsunterstützung /
Soporte de refrigeración y radiador / ラジエーターと冷却のサポート

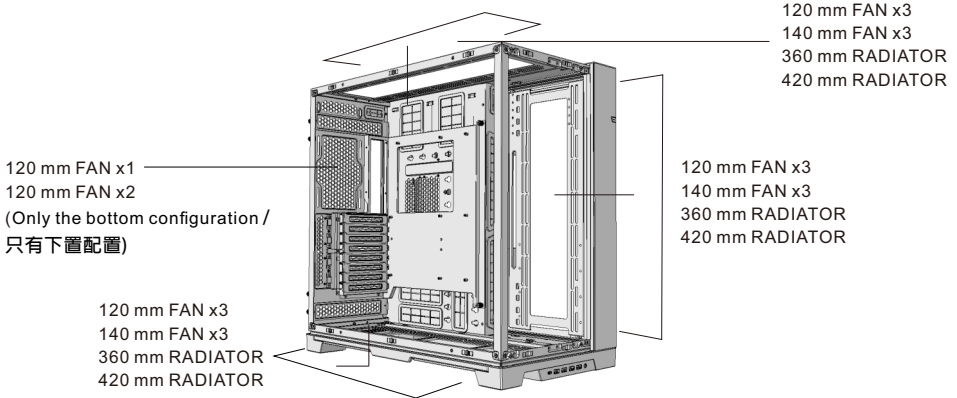

Remove the Top Fan Bracket

卸除上風扇支架 / Retirez le support du ventilateur supérieur / Entfernen Sie die obere Lüfterhalterung /
Retire el soporte del ventilador superior / 上部ファンブラケットを取り外します

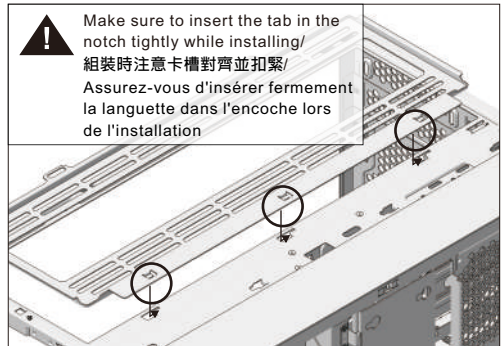
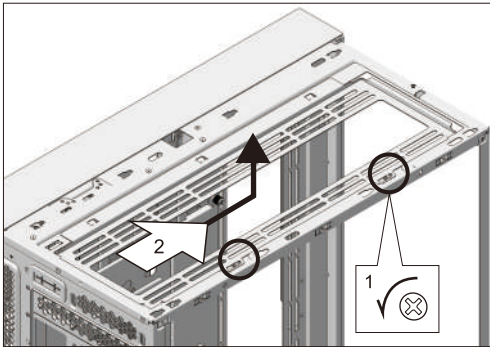

Remove the Bottom Fan Bracket

卸除下風扇支架 / Retirez le support inférieur du ventilateur / Entfernen Sie die untere Lüfterhalterung /
Retire el soporte del ventilador inferior / 下部ファンブラケットを取り外します

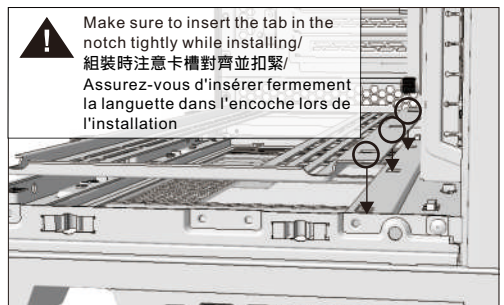
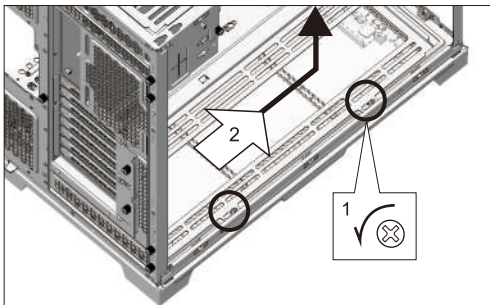

Remove the Side Fan Bracket

卸下側風扇支架 / Retirez le support du ventilateur latéral / Entfernen Sie die seitliche Lüfterhalterung /
Retire el soporte del ventilador lateral / サイドファンブラケットを取り外します

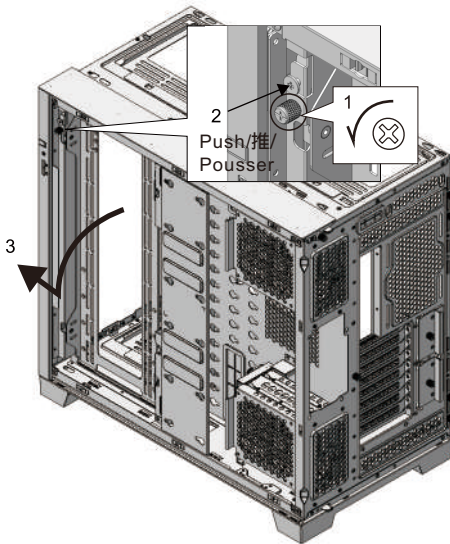

Use of seal plate/風扇架遮片使用方式/
Utilisation de la plaque d'étanchéité

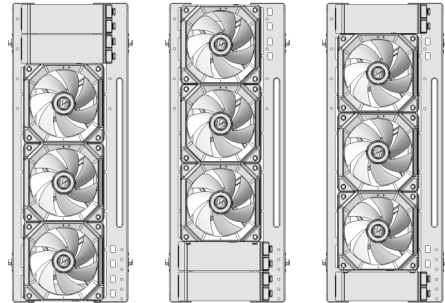
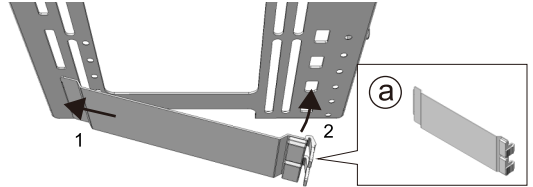

Attention: The fan bracket can be reversed, there are 4 installation style/風扇架可以反轉，有四種樣式/
Le support du ventilateur peut être inversé, il y a 4 styles d'installation

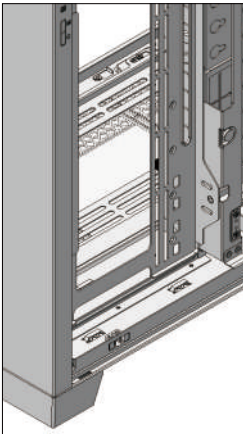

Style 1

Fans install toward the front panel/
樣式1(風扇靠前)/

Les ventilateurs s'installent vers le panneau avant

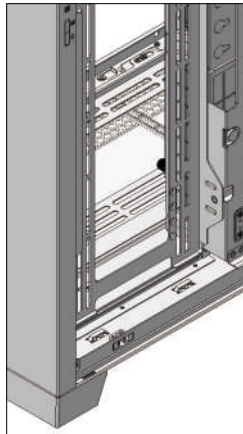

Style 2

Fans install toward the motherboard/
樣式2(風扇靠後)/

Les ventilateurs s'installent vers la carte mère

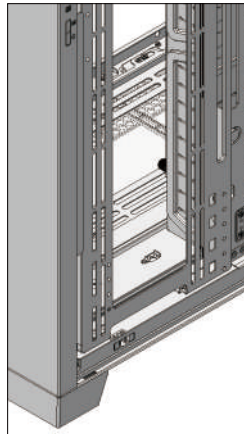

Style 3 (reversed)

Fans install toward the motherboard/
樣式3-反轉(風扇靠前)/

Les ventilateurs s'installent vers le panneau avant

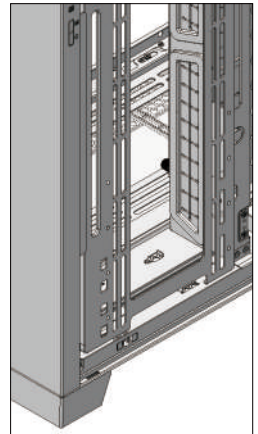

Style 4 (reversed)

Fans install toward the motherboard/
樣式4-反轉(風扇靠後)/

Les ventilateurs s'installent vers la carte mère

Graphic Card Anti-sag Bracket Installation

顯卡支撐架安裝 / Installation du support anti-affaissement de la carte graphique /

Installation der Anti-Sag-Halterung für die Grafikkarte / Instalación del soporte antideslizamiento de la tarjeta gráfica / グラフィックカードのたるみ防止ブラケットの取り付け

Installation 1 (For ATX MB) / 安裝 1 (ATX) / Installation 1 (pour ATX MB)

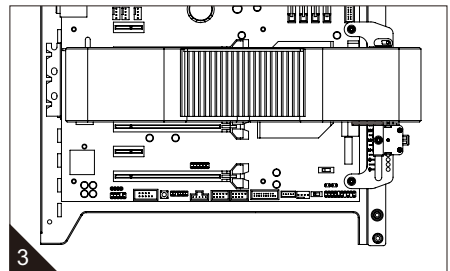
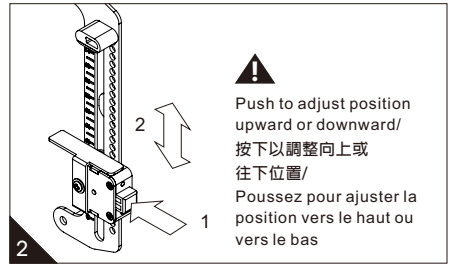
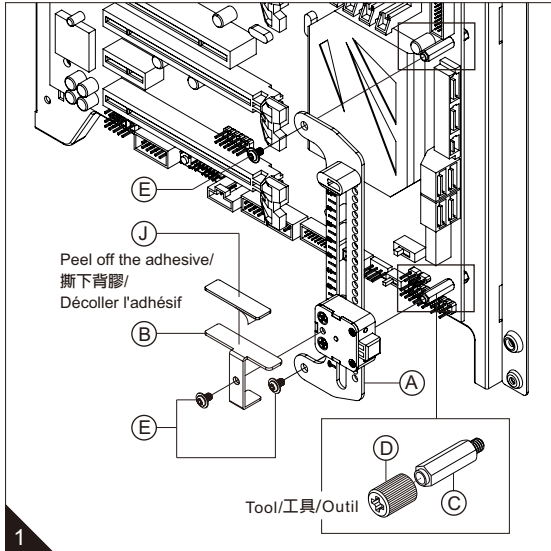

Installation 2 (For E-ATX MB) / 安裝 2 (E-ATX MB) / Installation 2 (pour E-ATX MB)

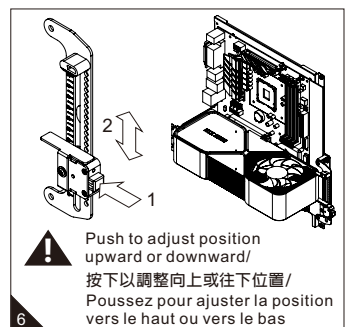
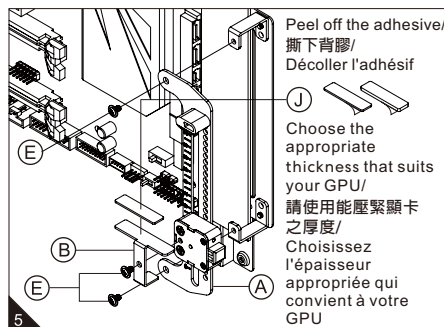
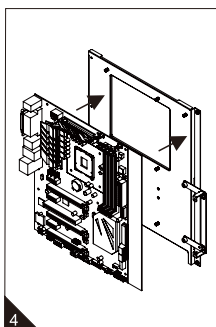
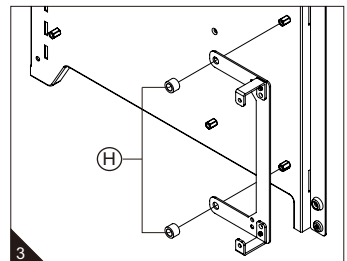
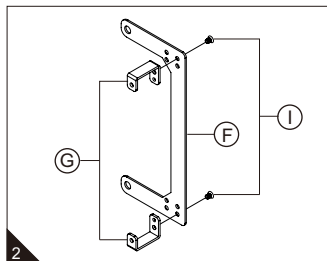
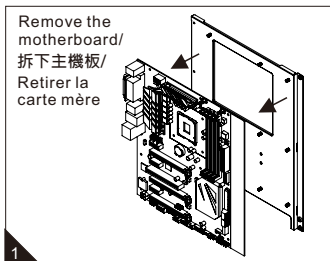

Right Side Panel Installation

右側板安裝 / Installation du panneau latéral droit / Montage der rechten Seitenwand /
Instalación del panel lateral derecho / 右側パネルの取り付け

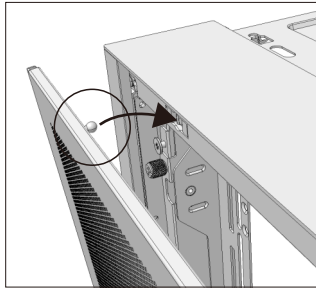
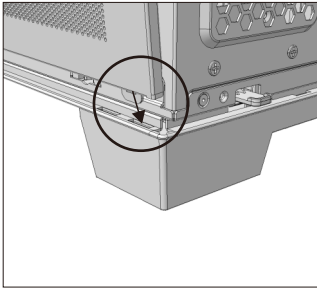

Side & Front Glass Panel Installation

側&前面玻璃安裝 / Pose des vitres latérales et frontales / Seiten- und Frontglasinstallation /
Instalación de vidrio lateral y frontal / 側面と前面のガラスの取り付け

Peel off the protective film on both sides/
撕下兩面的保護膜/
Décollez le film protecteur des deux côtés

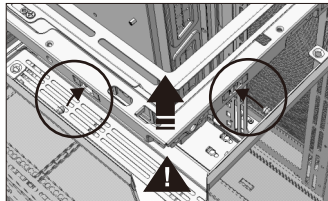
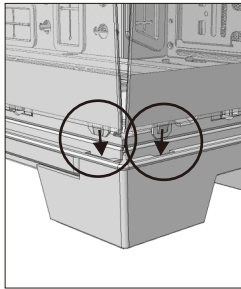
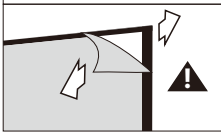

Gently lift the top frame to ensure the smooth installation/
將上板微微往上掀，以利安裝/Gently lift the top frame to ensure the smooth installation



Top Panel Installation

上蓋安裝 / Installation du capot supérieur / Montage der oberen Abdeckung / Instalación de la cubierta superior /
トップカバーの取り付け

Attention: Recommend to fix the screws of the side and front glass panel for transportation/
注意: 如需運送, 建議將側&前玻璃鎖上螺絲/
Attention : il est recommandé de fixer les vis du panneau de verre latéral et avant pour le transport

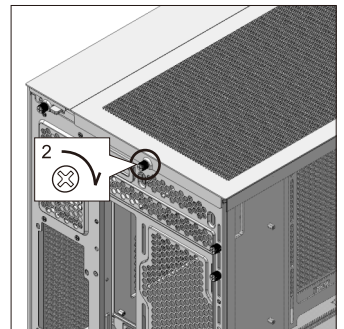
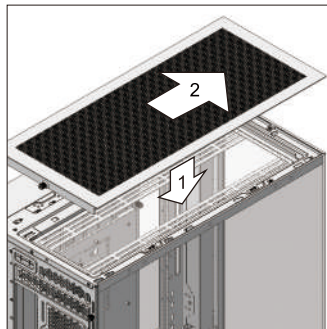
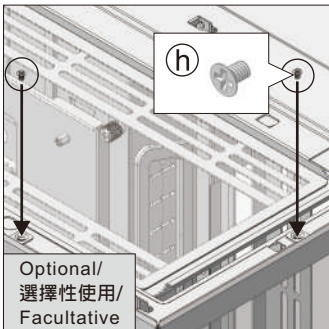

Reverse Mode Installation

Reverse

反向模式安裝 / Installation en mode inverse / Installation im umgekehrten Modus /
Instalación en modo inverso / リバースモードのインストール

- 1. Remove the top panel/卸上蓋/**
Retirer le panneau supérieur

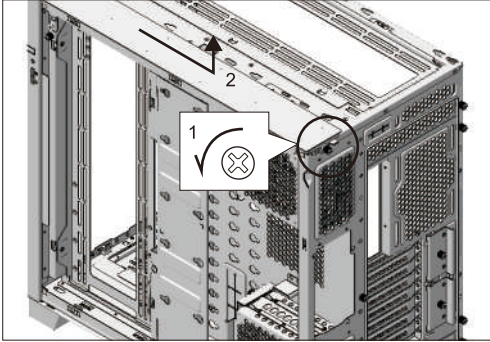

- 2. Remove the top fan bracket/卸除上風扇支架/**
Retirez le support du ventilateur supérieur

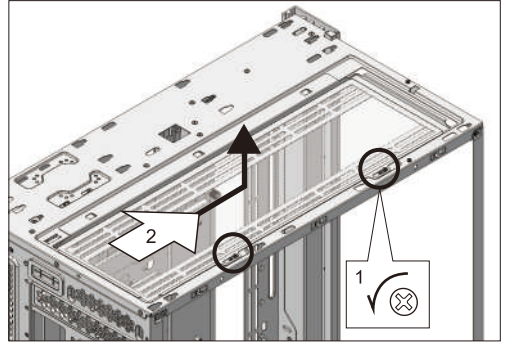

- 3. Remove the bottom fan bracket/卸除下風扇支架/**
Retirez le support inférieur du ventilateur

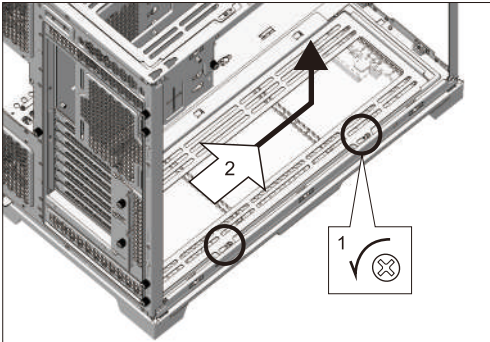

- 4. Flip the chassis and detach the bottom platform (Make sure the IO module is removed beforehand)/**
翻轉機箱並卸下腳座(先拔掉USB模組線材)/Retournez le châssis et détachez la plate-forme inférieure (assurez-vous que le module IO est retiré au préalable)

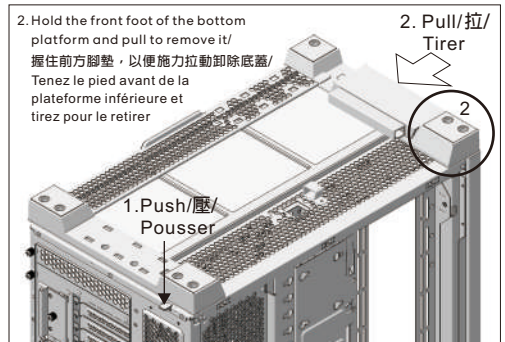

- 5. Flip the chassis and attach the bottom platform/**
將機殼前後翻轉180度後與腳座結合/
Retournez le châssis et fixez la plate-forme inférieure

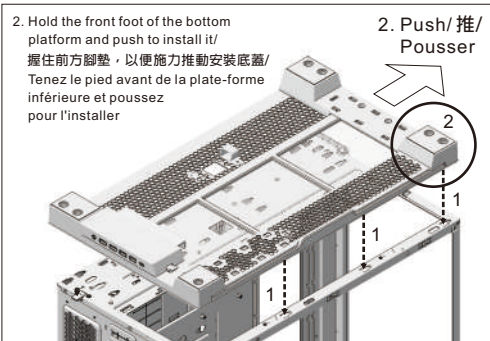

- 6. Switch the PSU support bracket to the other way around/**
將 PSU 支撐架移動到倒置使用的位置/Basculez le support du bloc d'alimentation dans l'autre sens

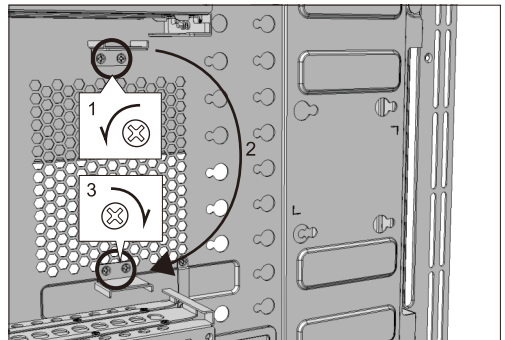

Reverse

2.5" SSD Installation

2.5" SSD 安裝 / Installation de 2.5" SSD /
2.5" SSD-Installation /
Instalación de 2.5" SSD /
2.5" SSD の取り付け

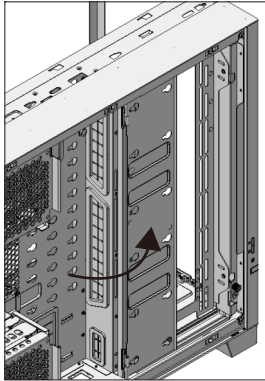

Way 1: Swing 180° to open /
使用方式一：翻轉180度 /
Méthode 1 : Pivoter à 180°
pour ouvrir

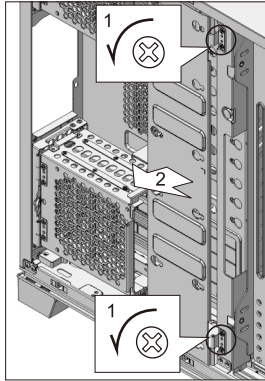

Way 2: Release /
使用方式二：取下 /
Voie 2 : Libérer

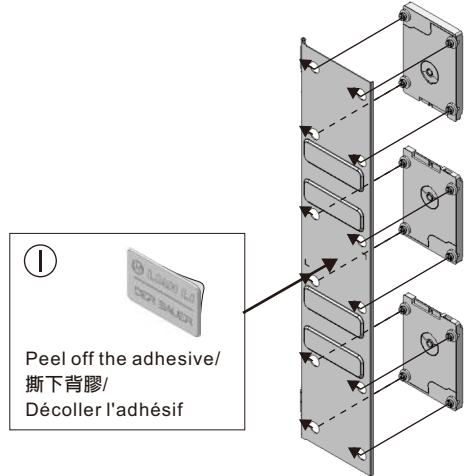
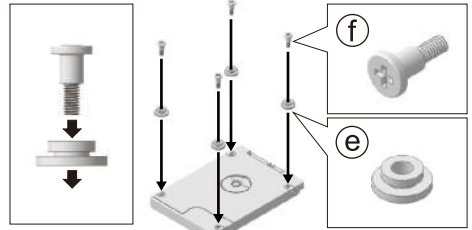

PSU Installation

電源供應器安裝 /
Installation du plateau du bloc d'alimentation /
PSU-Einsatz installieren /
Instalación de la fuente de alimentación /
電源のインストール

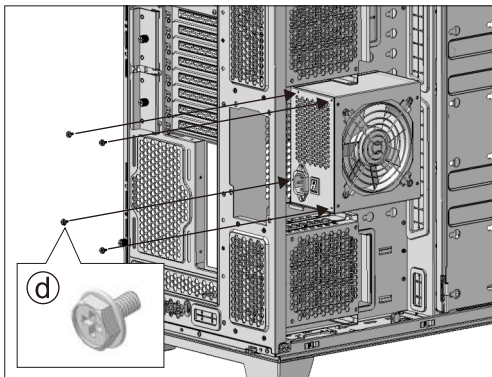

Remove the Dust Filters

灰塵濾網拆卸 /
Retirer les filtres à poussière /
Entfernen Sie die Staubfilter /
Retire los filtros de polvo /
防塵フィルターを取り外します

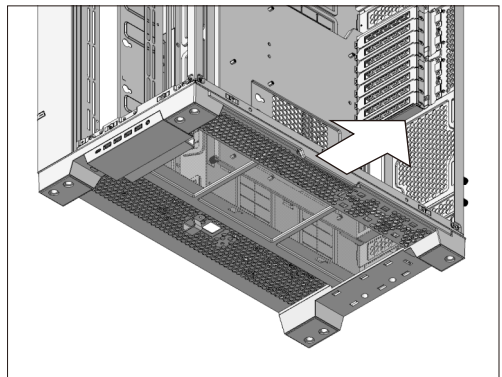

Reverse IO Module Location

I/O port 位置變換 / Changement de position du port d'E/S / Positionsänderung des I/O-Ports / Cambio de posición del puerto de E / S / I / Oポートの位置変更

Location 1 (Default mode) / 位置 1 (預設模式) /
Emplacement 1 (mode par défaut)

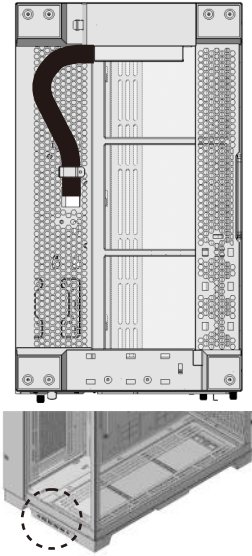

Location 2 / 位置 2 /
Emplacement 2

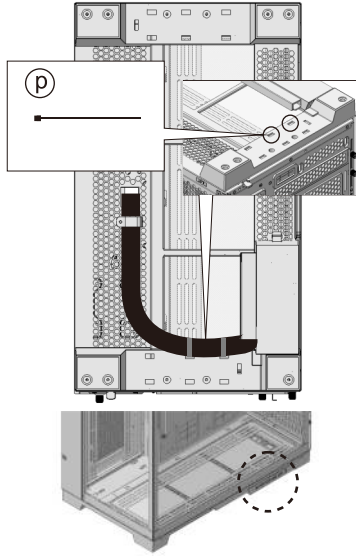

Location 3 / 位置 3 /
Emplacement 3

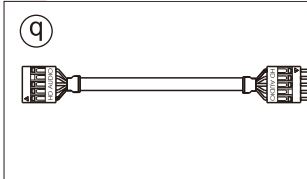
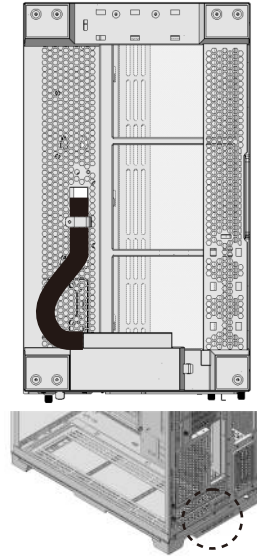

Use the HD Audio extension cab
使用HD audio延長線/
Utilisez le câble d'extension HD.

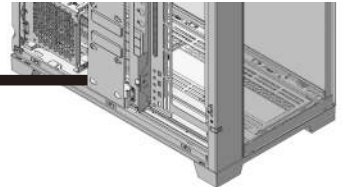

Remove the IO module / IO port 卸除 /
Retirer le module IO

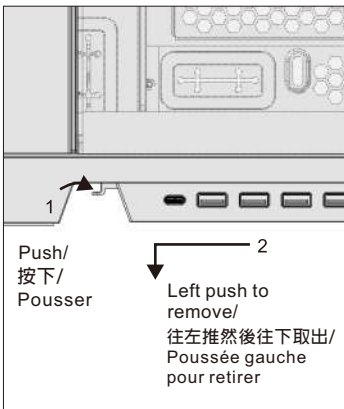

Remove the cable clip /
整線扣卸除 /
Retirer le serre-câble

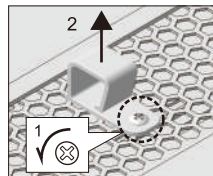

Install the cable clip /
整線扣安裝 /
Installez le serre-câble

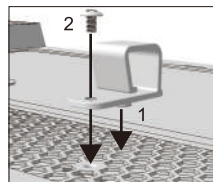

Route and fix the cable in different direction /
線材換方向走線固定 /
Acheminez et fixez le câble dans une direction
différente

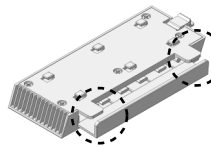

Move the cables to the
opposite direction
through the gap /
藉由缺口將線材拉出與
裝入凹位 /
Déplacez les câbles dans
la direction opposée à
travers l'espace



Cable orientation
for location 1 & 2 /
位置 1、2 適用 /
Orientation des
câbles pour les
emplacements 1 et 2 /

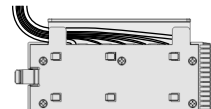

Cable orientation
for location 3 /
位置 3 適用 /
Orientation des câbles
pour l'emplacement 3

Reverse

Remove the motherboard tray and back plate

卸除後板與遮片 / Retirez le panneau arrière et le masque / Entfernen Sie die Rückwand und die Maske / Retire el panel posterior y la máscara / バックパネルとマスクを取り外します

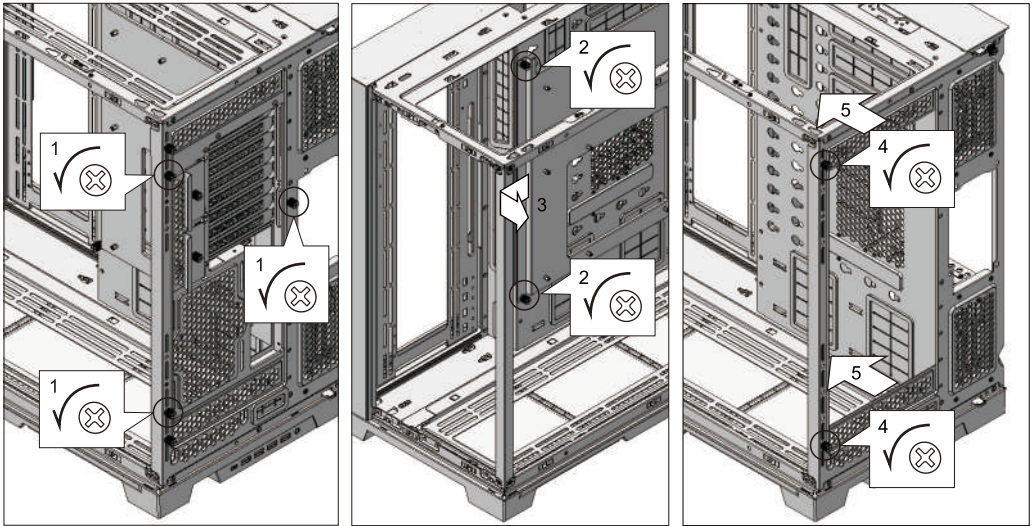

Motherboard Installation

主板安裝 / Installation de la carte mère / Mainboard-Installation / Instalación de la placa base / マザーボードの取り付け

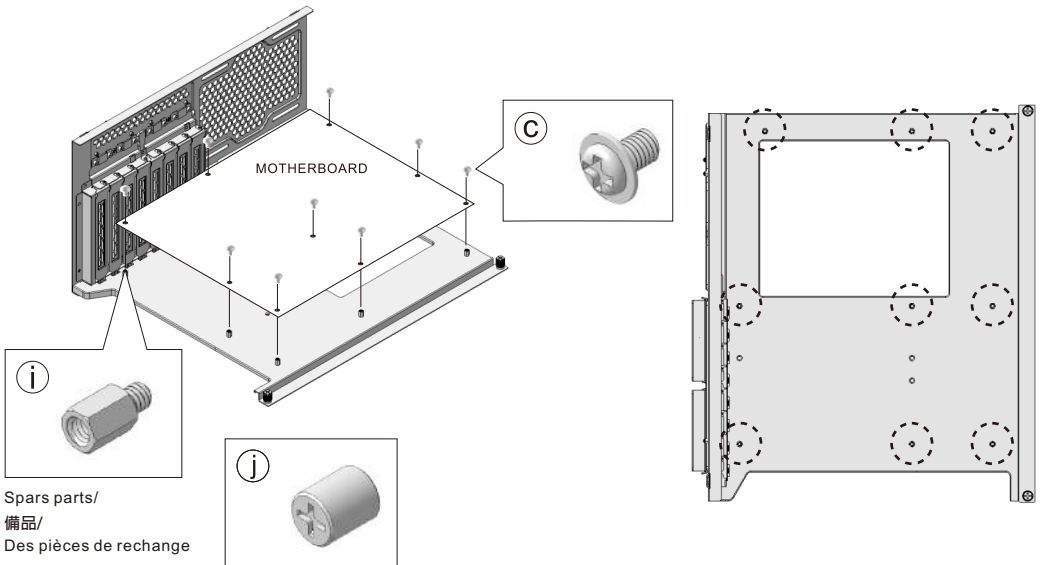

Spars parts/
備品/
Des pièces de rechange

Tool/工具/Outil

Reverse

Install the back plate and the motherboard tray

安裝後板與遮片 / Installez la plaque arrière et le masque / Installieren Sie die Rückplatte und die Maske / Instale la placa posterior y la máscara / バックプレートとマスクを取り付けます

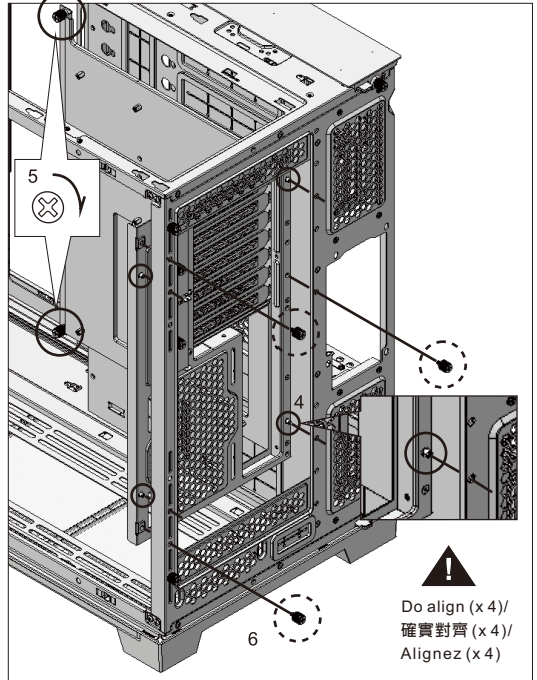
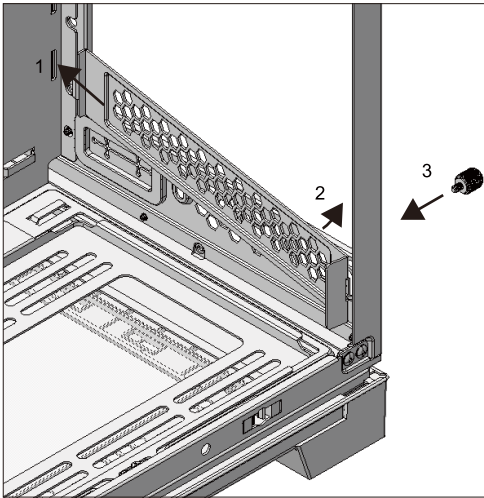

Schema of the modes

配置示意圖 / Schéma de configuration / Konfigurationsdiagramm / Diagrama de configuración / 構成のヒント

○ Screw here
圓框處請鎖上螺絲
Visser ici

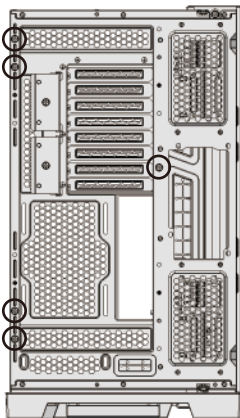

Middle Mode (Factory Default) / 出廠配置 / Mode moyen (valeur par défaut)

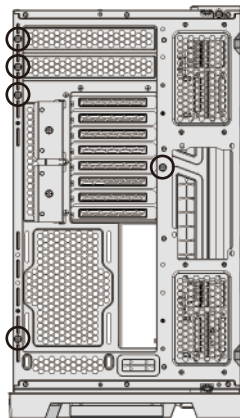

Low Mode / 下置配置 / Mode bas

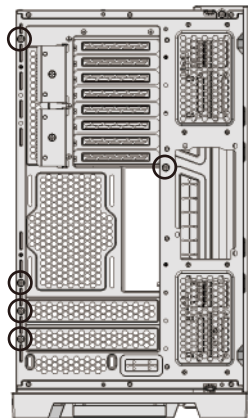

Top Mode / 上置配置 / Mode supérieur

Reverse

Graphics card installation

顯示卡安裝 / Installation de la carte graphique / Grafikkarteninstallation /
Instalación de tarjeta gráfica / グラフィックカードの取り付け

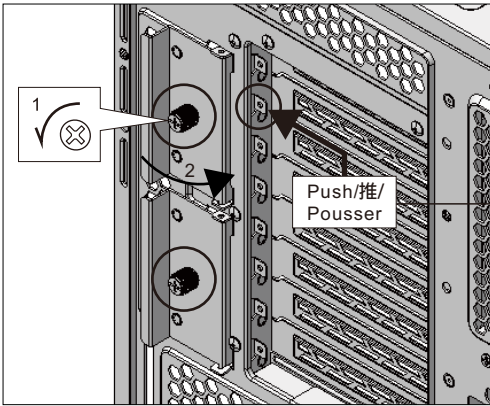

Push to release bracket/
推開拿出空片/
Pousser pour libérer le support

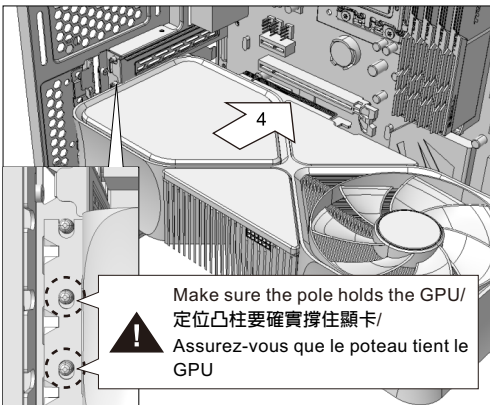

! Make sure the pole holds the GPU/
定位凸柱要確實撐住顯卡/
Assurez-vous que le poteau tient le GPU

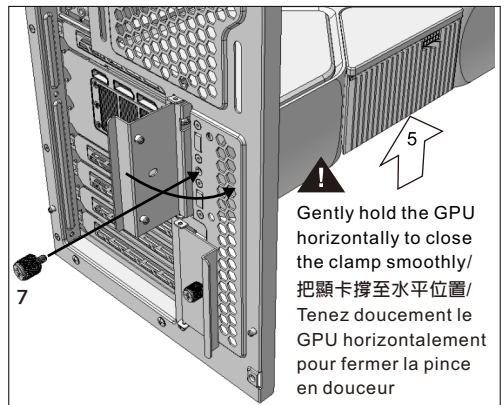

! Gently hold the GPU horizontally to close the clamp smoothly/
把顯卡撐至水平位置/
Tenez doucement le GPU horizontalement pour fermer la pince en douceur

Remove the Pillar

立柱卸除方式 / Column removal method /
Methode zum Entfernen von Säulen /
Método de eliminación de columnas /
カラムの取り外し方法

! Make sure to fix the pillar for transporting/
如需運送，務必將立柱鎖上/
Assurez-vous de fixer le pilier pour le transport

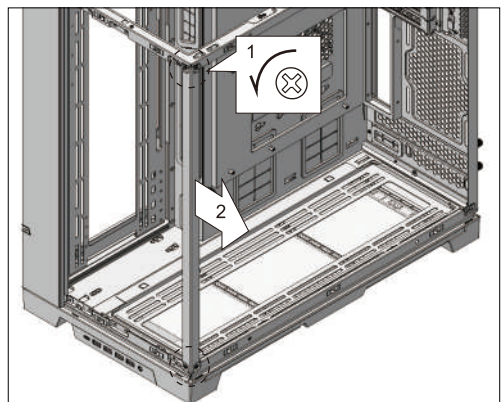

Reverse 2.5" SSD, 3.5" HDD Installation

2.5" SSD, 3.5" HDD 安裝 / Installation de 2.5" SSD, 3.5" HDD / 2.5" SSD, 3.5" HDD-Installation / Instalación de 2.5" SSD, 3.5" HDD / 2.5" SSD, 3.5" HDD の取り付け

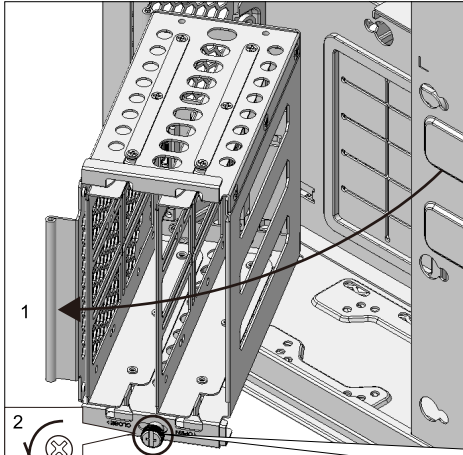

Loosen the screw, do not completely remove it / 轉鬆即可切勿取下 / Desserrez la vis, ne la retirez pas complètement

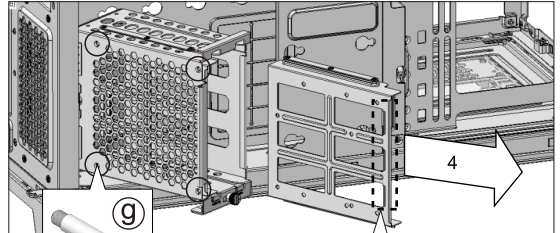

15 mm thick fans can be installed outside the HDD cage / 硬碟籠外側可安裝 15 mm 厚度風扇 / Des ventilateurs de 15 mm d'épaisseur peuvent être installés à l'extérieur de la cage HDD



Grab the notch to remove the tray / 手指勾著溝槽便於施力移除托盤 / Saisissez l'encoche pour retirer le plateau

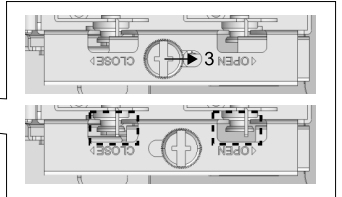

2.5" SSD Installation



Pay attention to the installation direction / 注意安裝方向 / Attention au sens de pose

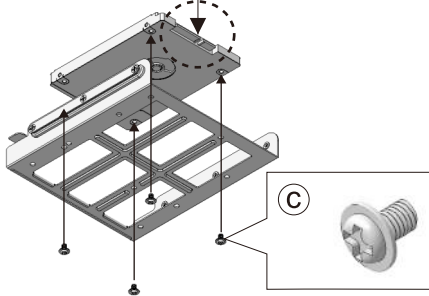

3.5" HDD Installation

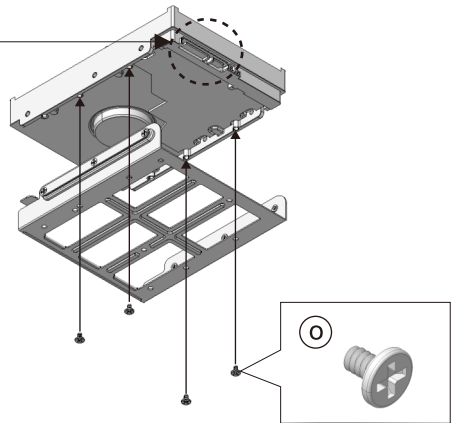

Cable connection / 線材連接 / Câble de connexion



Connecting to Motherboard / 連接至主板 / Connexion à la carte mère

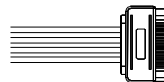

Connecting to PSU / 連接至電源 / Connexion au bloc d'alimentation

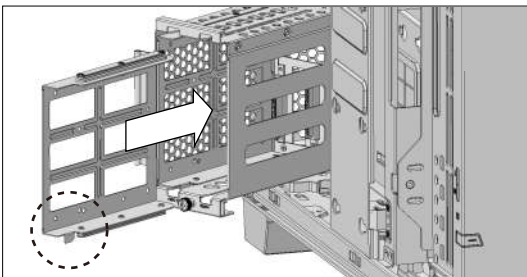

Reverse

Cable Management

線材整理 / Gestion des câbles /
Kabelmanagement / Mantenimiento
de cable / ケーブル管理

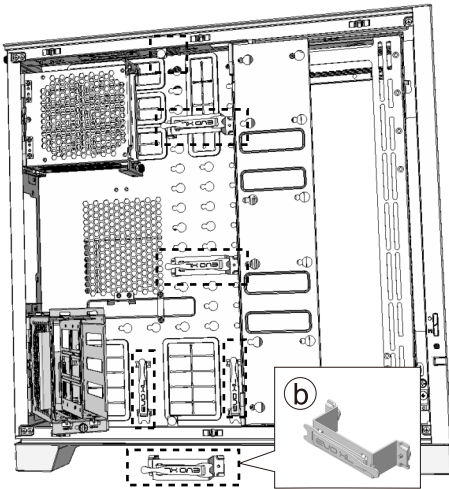

Cable Holder Installation

整線扣安裝方式 / Installation complète de la boucle du
câble / Installation der gesamten Kabelschnalle /
Instalación de hebilla de cable completo /
全ラインバックルの取り付け

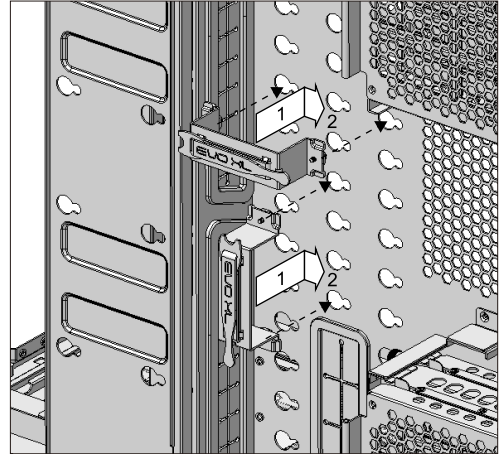

Use of Cable Holder

整線扣整線說明 / Description complète de la ligne complète de la boucle du câble / Ganze Beschreibung der
gesamten Kabelschnalle / Descripción de toda la línea de hebilla de cable completo / バックル全体 ライン全体

Keep the big cables in the cable holders/
先將粗線整在金屬框架內/
Gardez les gros câbles dans les
porte-câbles

Hold the small cables with the velcro straps/
再將細線使用魔鬼氈整好/
Maintenez les petits câbles avec les bandes
velcro

Remove the velcro strap to place a
controller/
亦可拆下魔鬼氈作為控制器黏貼處/
Retirez la bande velcro pour placer un
contrôleur

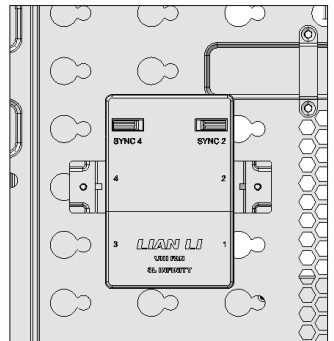
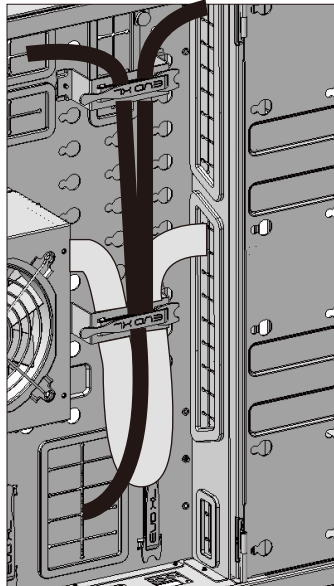
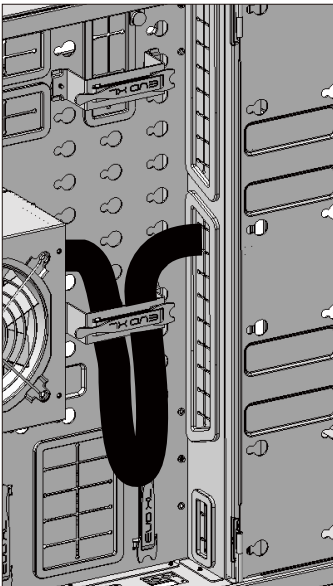

Reverse Radiator & Cooling Support

Reverse

散熱器&水冷排支援 / Radiateur et ventilation compatibilité / Kühler- und Kühlungsunterstützung / Soporte de refrigeración y radiador / ラジエーターと冷却のサポート

120 mm FAN x3
140 mm FAN x3
360 mm RADIATOR
420 mm RADIATOR

120 mm FAN x3
140 mm FAN x3
360 mm RADIATOR
420 mm RADIATOR

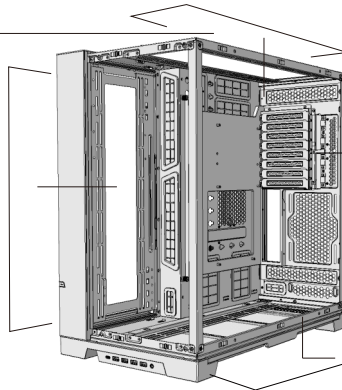

120 mm FAN x1
120 mm FAN x2
(Only the bottom configuration / 只有下置配置)

120 mm FAN x3
140 mm FAN x3
360 mm RADIATOR
420 mm RADIATOR

Install the Top Fan Bracket

安裝上風扇支架 / Installer le support de ventilateur supérieur / Installieren Sie die obere Lüfterhalterung / Instale el soporte del ventilador superior / 上部ファンブラケットを取り付けます

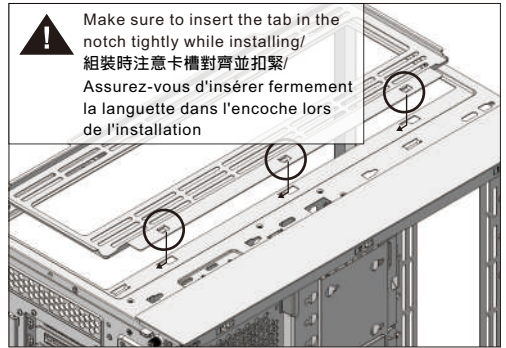
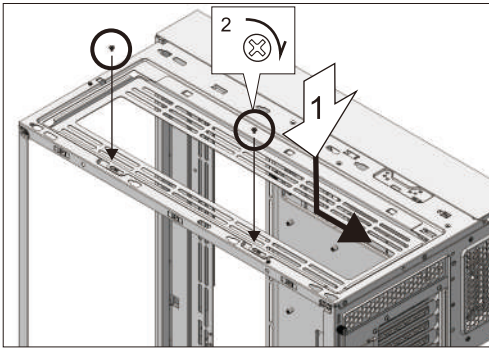

Bottom Fan Bracket Installation

安裝下風扇支架 / Installation du support inférieur du ventilateur / Installation der unteren Lüfterhalterung / Instalación del soporte del ventilador inferior / 下部ファンブラケットの取り付け

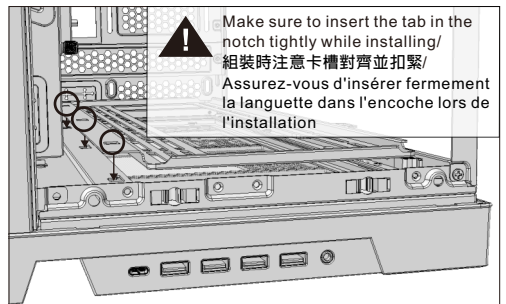
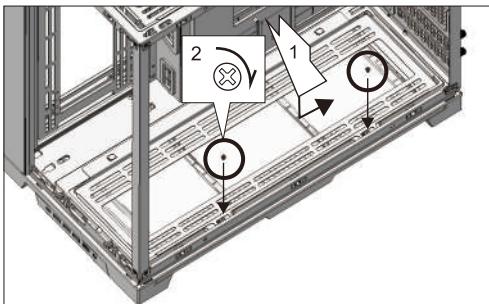

Reverse Remove the Side Fan Bracket

Reverse

卸下側風扇支架 / Retirez le support du ventilateur latéral / Entfernen Sie die seitliche Lüfterhalterung
/ Retire el soporte del ventilador lateral / サイドファンブラケットを取り外します

Use of seal plate/風扇架遮片使用方式/
Utilisation de la plaque d'étanchéité

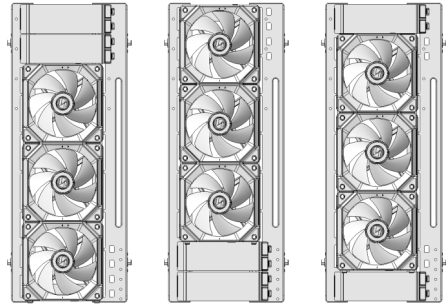
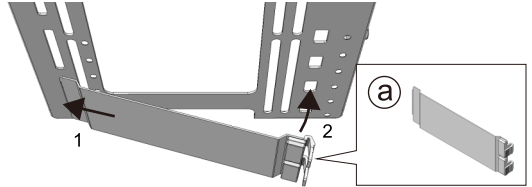
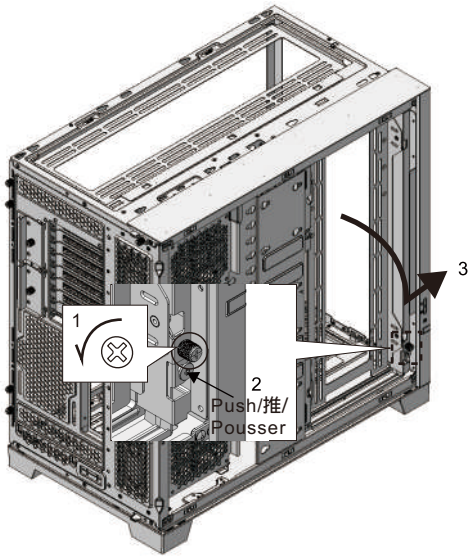

Attention: The fan bracket can be reversed, there are 4 installation style/風扇架可以反轉，有四種樣式/
Le support du ventilateur peut être inversé, il y a 4 styles d'installation

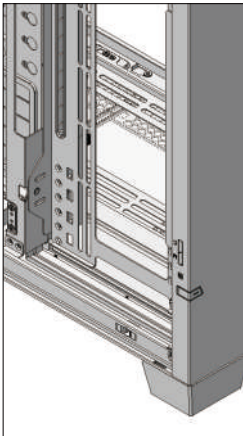

Style 1

Fans install toward the front panel/
樣式1(風扇靠前)/

Les ventilateurs s'installent vers le panneau avant

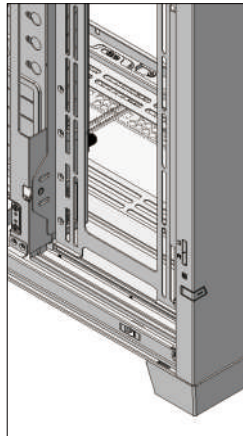

Style 2

Fans install toward the motherboard/
樣式2(風扇靠後)/

Les ventilateurs s'installent vers la carte mère

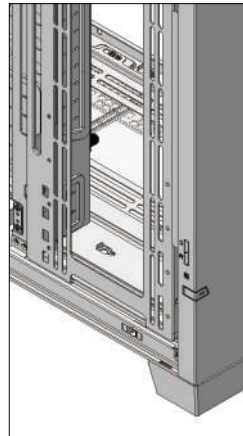

Style 3 (reversed)

Fans install toward the front panel/
樣式3-反轉(風扇靠前)/

Les ventilateurs s'installent vers le panneau avant

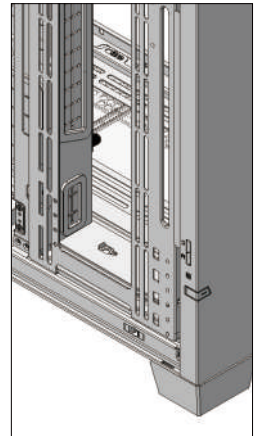

Style 4 (reversed)

Fans install toward the motherboard/
樣式4-反轉(風扇靠後)/

Les ventilateurs s'installent vers la carte mère

Graphic Card Anti-sag Bracket Installation

顯卡支撐架安裝 / Installation du support anti-affaissement de la carte graphique /

Installation der Anti-Sag-Halterung für die Grafikkarte / Instalación del soporte antideslizamiento de la tarjeta gráfica / グラフィックカードのたるみ防止ブラケットの取り付け

Installation 1 (For ATX MB)/安裝 1 (ATX)/Installation 1 (pour ATX MB)

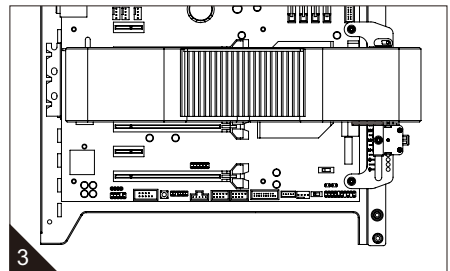
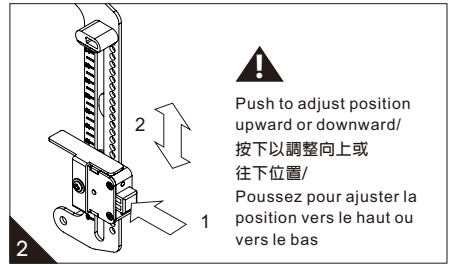
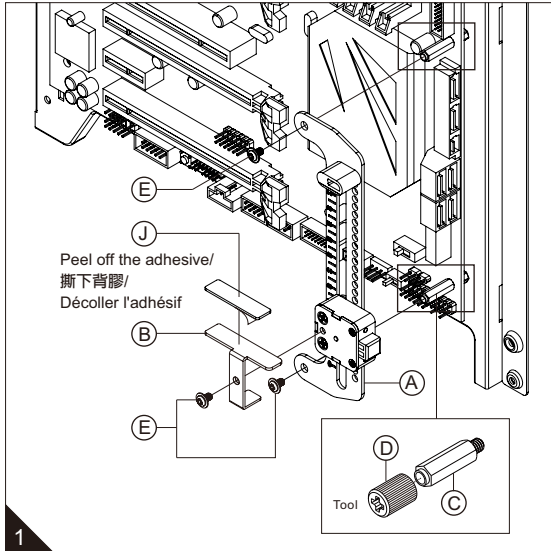

Installation 2 (For E-ATX MB)/安裝 2 (E-ATX MB)/Installation 2 (pour E-ATX MB)

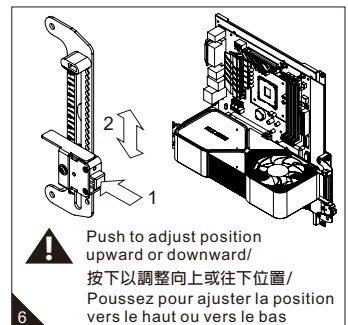
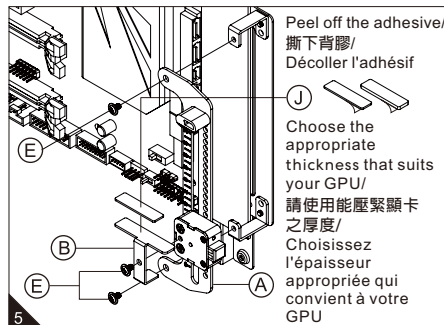
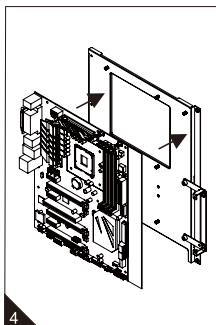
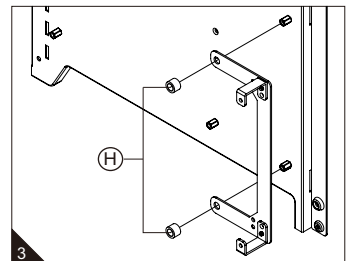
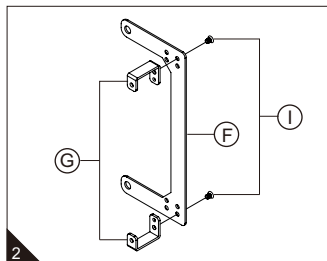
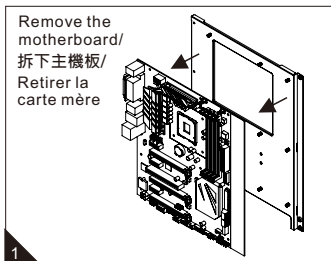

Reverse

Right Side Panel Installation

右側板安裝 / Installation du panneau latéral droit / Montage der rechten Seitenwand /
Instalación del panel lateral derecho / 右側パネルの取り付け

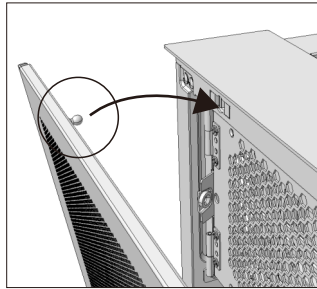
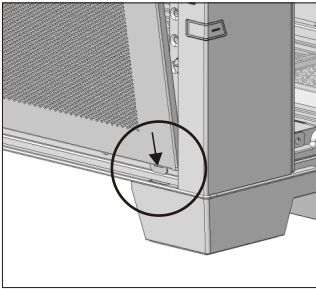

Side & Front Glass Panel Installation

側&前面玻璃安裝 / Pose des vitres latérales et frontales / Seiten- und Frontglasinstallation /
Instalación de vidrio lateral y frontal / 側面と前面のガラスの取り付け

Peel off the protective film on both sides/
撕下兩面的保護膜/
Décollez le film protecteur des deux côtés

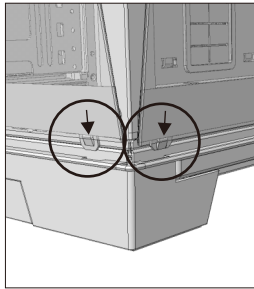
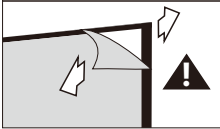

Gently lift the top frame to ensure the smooth installation/
將上板微微往上掀，以利安裝/Gently lift the top frame to ensure the smooth installation

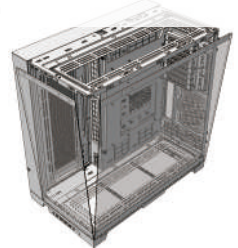
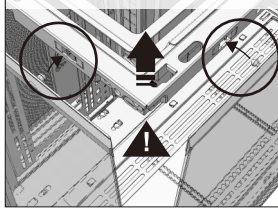

Top Panel Installation

上蓋安裝 / Installation du panneau supérieur / Installation der oberen Platte / Instalación del panel superior /
トップカバーの取り付け



Attention: Recommend to fix the screws of the side and front glass panel for transportation/
注意: 如需運送, 建議將側&前玻璃鎖上螺絲/
Attention : il est recommandé de fixer les vis du panneau de verre latéral et avant pour le transport

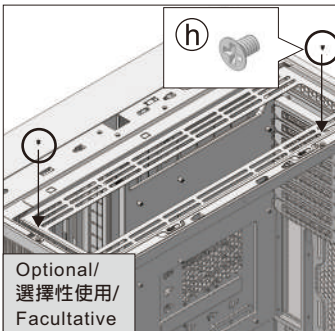

Optional/
選擇性使用/
Facultative

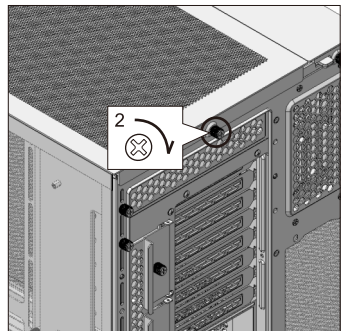
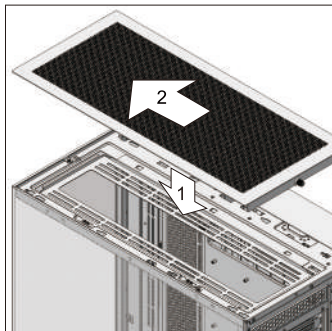

Hardware Clearance

硬體擴充支援 / Liquidation du matériel / Hardware-Freigabe / Liquidación de hardware / ハードウェアクリアランス

CPU height clearance/CPU高度間隙/
Dégagement en hauteur du processeur

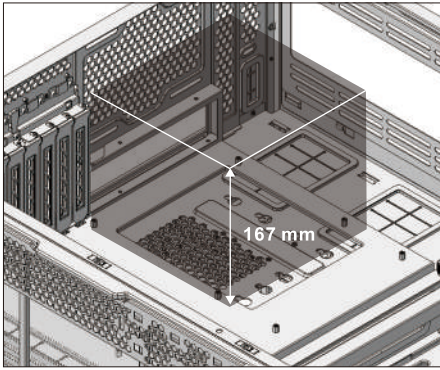

GPU clearance/GPU間隙/Dégagement GPU

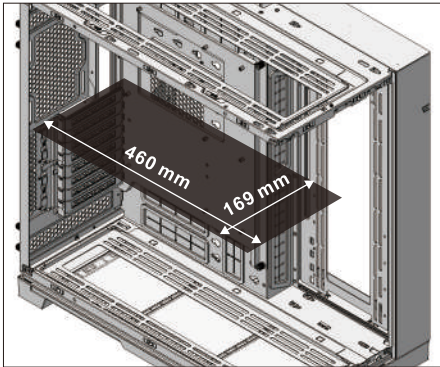

Radiator and fan combo height clearance/
散熱器和風扇組合高度間隙/Dégagement combiné en
hauteur du radiateur et du ventilateur

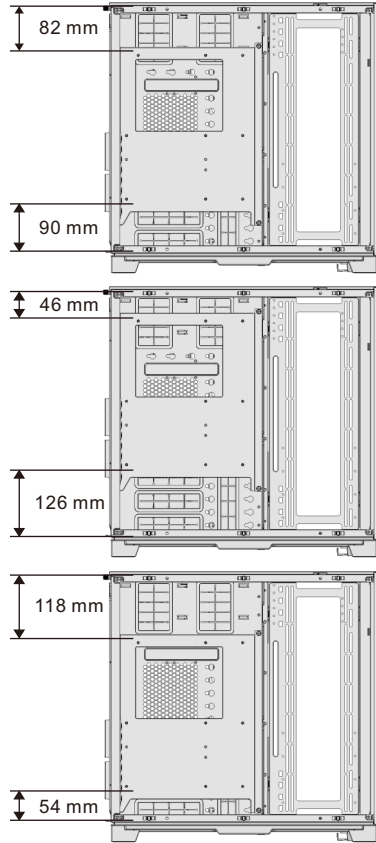

Option Kits

選配套件 / Kits d'options / Optionssätze / Kits de opciones / オプションキット

PW-PCIV-4-90X / PW-PCIV-4-90W
900mm PCIe 4.0 riser cable

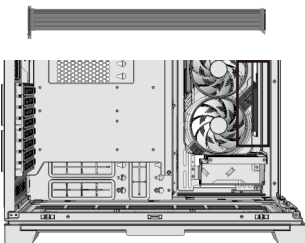

O11DEXL-1X / O11DEXL-1W
Upright GPU Bracket

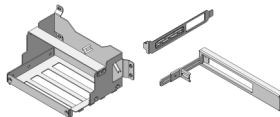

VG4-4-V2X / VG4-4-V2W
Universal 4- Slots Vertical GPU kit
(with Gen 4 riser)

